

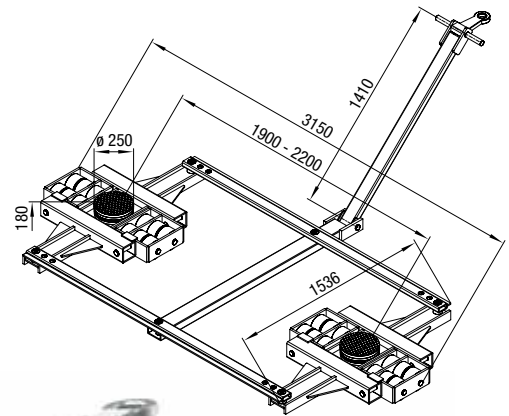

Carrelli di trasporto TL60 ►► Per carichi pesanti fino a 60 tonnellate

- Caratteristiche:**
- Utilizzando il sistema tandem si effettuano curve di raggio minore
 - Combinabili con il carrello F60 per carichi fino a 120 t

Dati tecnici	TL60
Codice articolo	12035
Altezza di caricamento / Numero di ruote (140 x 85 mm)	180 mm / 24
2 piattaforme girevoli ø 250 mm, angolo di sterzata	± 40°
Regolabile su 3 posizioni	1175*
Barra di guida con anello di traino	1620 mm
Peso proprio	570 kg
Portata	600 kN (60 t)

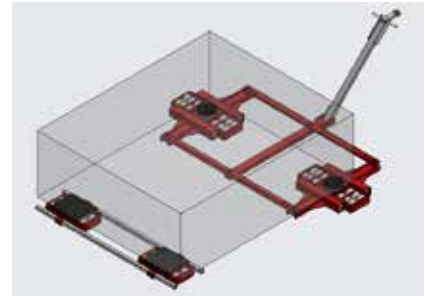

- Indice
- Sollevatori idraulici
- Pompe
- Carrelli di trasporto
- Carrelli girevoli
- Sistema di trasporto ROBOT
- Ruote
- Mezzi speciali
- Riparazione